



Model: All Serial #: N/A	Feb. 3, 2020
Product Bulletin # TDS-212 v 1.0	

Washpipe Assembly, 3 in Bore, 7.5K

Canrig Drilling Technology has developed a new washpipe available for use in either a Canrig or Tesco Top Drive with a 3 in. fluid passage and 7,500 psi rating (See Figure 1 and Figure 2). This new washpipe is offered in the following 4 options:

- **Regular Service (RS):** For routine drilling operations.
- **Extended Service (ES):** For routine drilling operations, but allows for the reuse of the washpipe during packing change.
- **Severe Service 1 (SS-1):** High pressure and high RPM applications up to 398 RPM.
- **Severe Service 2 (SS-2):** High pressure and high RPM applications up to 417 RPM.



Figure 1: Canrig Washpipe Assembly



Figure 2: Tesco Washpipe Assembly



Model: All Serial #: N/A	Feb. 3, 2020
-----------------------------	--------------

New Washpipe Features include:

- Taller lower nut with an additional spacer to pre-energize and lock the outer diameter of the packing rings (offered on Regular Service, Extended Service, and Severe Service options).
- New washpipe barrel has an improved wear surface for longer service life (offered on Extended Service and Severe Service options).
- New packing rings include a special low-friction enhancement on its internal diameter to improve performance and reduce start up friction (offered on Severe Service option only).
- Lower and upper nut only requires a hand tool, round bar, for installation (offered on Regular Service, Extended Service, and Severe Service options).

New Washpipe Benefits

- The use of hand tools for tightening or loosening the washpipe assembly reduces operational time for washpipe packing replacement.
- Eliminating the use of hammer on this washpipe installation offers a safer product, reduced safety risk and cost associated with occupational injuries.
- New washpipe barrel designed for higher rotational speeds and longer service life (offered only on Extended Service and Severe Service options).

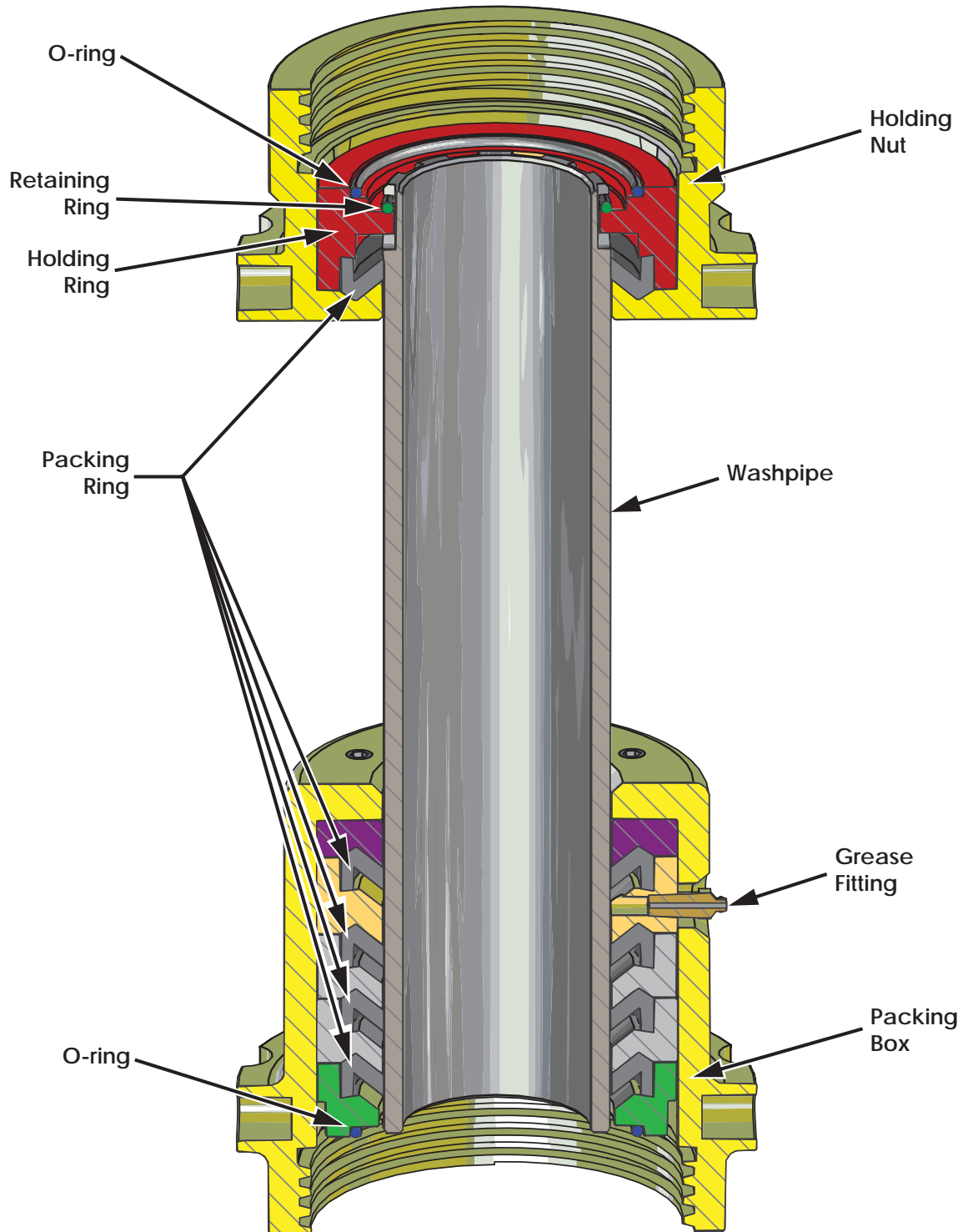

Figure 3: Washpipe Assembly Cross-section

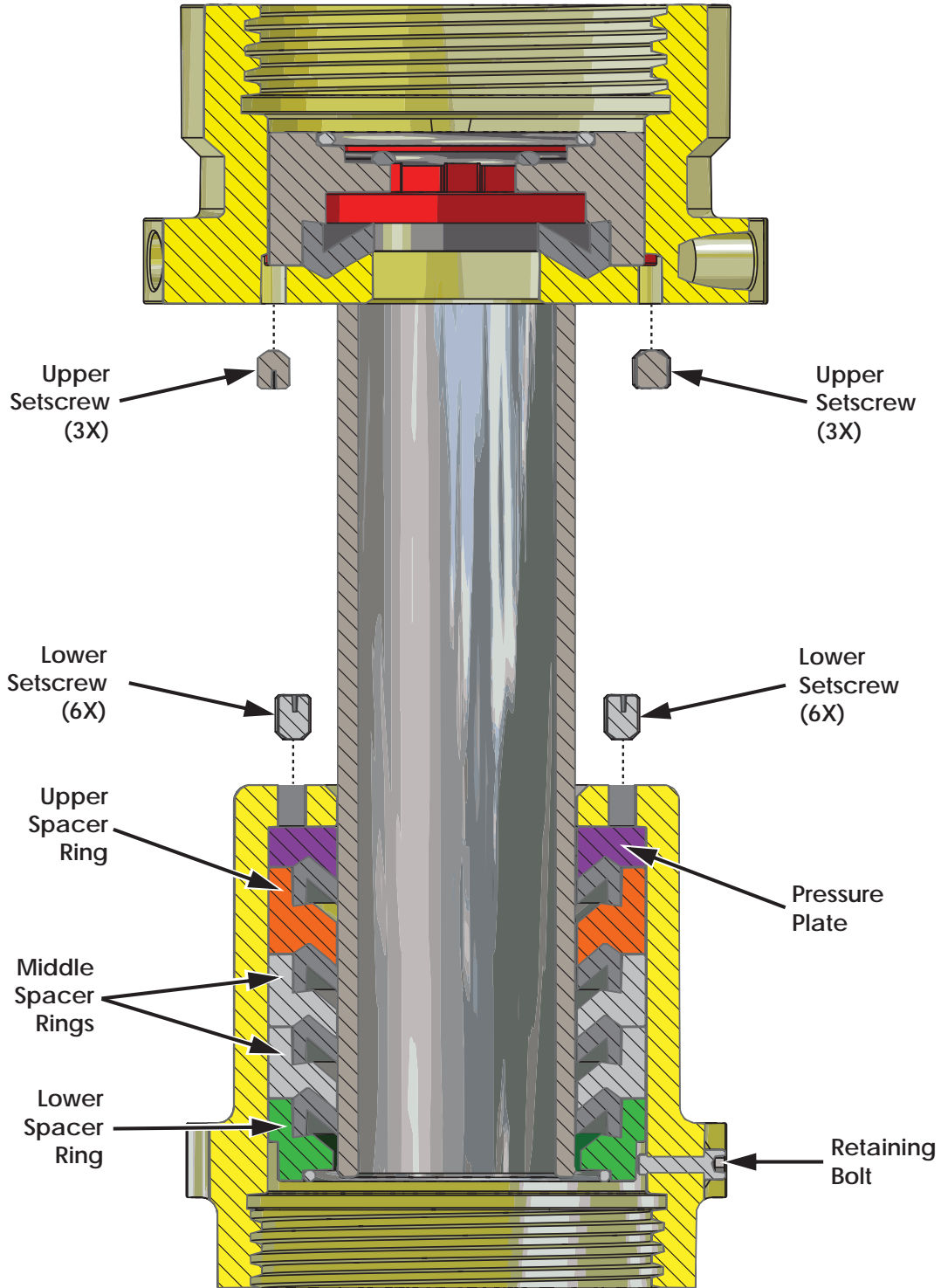

Figure 4: Washpipe Assembly Cross-section



Model: All	Feb. 3, 2020
Serial #: N/A	

Contact RIGLINE 24/7™ Support to order the new washpipe. Use the tables below to order correct assemblies and spare parts.

CANRIG Washpipes				
Washpipe Assembly, 3 in. Bore, 7.5 ksi, WP-3				
Application	For routine drilling operations	Allows reuse of the washpipe during a packing change	High Pressure / High RPM application	
Service	Regular (RS)	Extended (ES)	Severe 1 (SS-1)	Severe 2 (SS-2)
Assembly w/Tool Kit	AY23110-1	AY22862-1	AY24096-1	AY23108-1
Barrel	DT17943	DT36195	DT36195	DT36195
Packing Canrig P/N	UTEX 0730 R01-1002-040	UTEX 0730 R01-1002-040	UTEX 0734 R10499	UTEX 0738 R10451
Spare Kit	AY23111	AY22870	AY24097	AY23109

TESCO Washpipes			
Washpipe Assembly, 3 in. Bore, 7.5 ksi, WP-3			
Application	Allows reuse of the washpipe during a packing change	High Pressure / High RPM application	
Service	Extended (ES)	Severe 1 (SS-1)	Severe 2 (SS-2)
Assembly w/Tool Kit	AY24150-1	AY24152-1	AY24154-1
Barrel	DT24752	DT24752	DT24752
Packing Canrig P/N	UTEX 0730 R01-1002-040	UTEX 0734 R10499	UTEX 0738 R10451
Spare Kit	AY24151	AY24153	AY24155